

THE ELEMENT OF TIME IN THE PHOTOELECTRIC EFFECT

BY ERNEST O. LAWRENCE AND J. W. BEAMS

ABSTRACT

Time of appearance and cessation of the photoelectric effect from a potassium hydride surface.—A method has been devised which has made possible the study of the time variation of the photoelectric emission from a metal surface illuminated by light flashes of 10^{-8} sec. duration. The experimental arrangement has also yielded information on the speed of operation of the Kerr cell electro-optical shutter described in earlier work and has made possible for the first time the observation of the steepness of wave fronts traveling along wires resulting from spark discharges. Photoelectric emission begins in less than 3×10^{-9} sec. after the beginning of the illumination of a potassium hydride surface. The light shutter closes less abruptly than it opens and the experimental observations indicate that the sum of the time required for the shutter to close plus the time during which the photoelectric emission persists after cessation of irradiation is less than 10^{-8} sec. A wave traveling along a wire resulting from the sudden change of potential of one end by a spark discharge is so steep that the time necessary for about half the wave-front to pass a point 6 meters along the wire is 4.5×10^{-9} sec. Theoretical considerations bearing on these results are discussed.

INTRODUCTION

THE classical observations by Wien¹ and Dempster² of the decay of luminosity in a canal-ray beam have shown that the excitation of atoms and emission of light by atoms are not simultaneous events. Absorption and emission of light and the photoelectric effect are complementary atomic processes, and it is therefore of especial interest to inquire as to the course of events wherein electrons are ejected from atoms by radiation. How soon are electrons emitted from a metal surface after it is irradiated by light and in what manner does the electron emission persist after cessation of the illumination? The experiments described below have given an answer to this fundamental query.

METHOD

In order to study the element of time in the photoelectric effect it was necessary to devise a method capable not only of irradiating a metal surface for known intervals of time of about 10^{-8} sec but also capable of detecting at what instants relative to the time of irradiation electrons are ejected, again with precision greater than 10^{-8} sec.

In earlier work we³ have described a method for producing short flashes of light. Two similar Kerr cells K_1 and K_2 (Fig. 1) were placed between crossed Nicol prisms N_1 and N_2 with the normals to their plate surfaces at right angles to each other. Thus, when the electric fields between the plates

¹ W. Wien, Ann. d. Physik **73**, 483 (1924).

² A. J. Dempster, Astrophys. J. **57**, 193 (1923).

³ Lawrence and Beams, Proc. Natl. Acad. Sci. **13**, 207 (1927).

of both cells were of the same magnitude the cells compensated each other and light emerging from the second cell was plane polarized and unable to pass through the crossed Nicol N_2 . Only when the electric field in one cell was greater than in the other was there double refraction causing light to pass through N_2 . The Kerr cell plates were attached to a spark gap SG so that at a time after the beginning of the spark discharge equal to the length of wire connecting the cells to SG divided by the velocity of light the cells began their discharge. By using wire paths of different lengths to K_1 and K_2 the cells could be made to begin to discharge at times differing by as short intervals as desired. Thus, during these short time intervals light passing through K_1 and K_2 was doubly refracted and passed through N_2 .

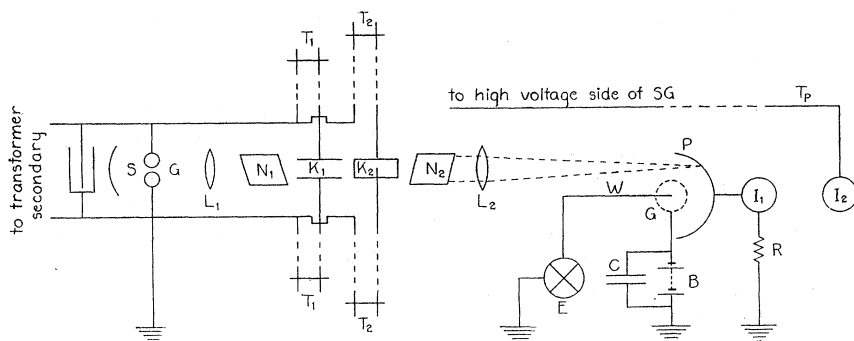

Fig. 1. Arrangement of apparatus.

Short light-flashes produced in this manner illuminated a potassium hydride surface P of a three-electrode photoelectric cell (Fig. 1). A brass ball I_1 (2 cm diam.) was attached to the electrode of P on the outside of the photoelectric cell and another brass ball I_2 , which was attached to a wire T_p of variable length connected to the high voltage electrode of the spark gap, was placed at a distance from I_1 of usually from 10 to 15 cm. An india-ink resistance R of about 10^{10} ohms attached to the plate system maintained P at earth potential excepting when a change of the potential of I_2 quickly induced a change in potential of I_1 . A grid G surrounding a collecting electrode W was maintained at a definite negative potential by a bias battery B of several hundred volts. A condenser C of one microfarad capacity maintained the potential of G constant even though the potential of P changed by several hundred volts in very short time intervals. The collecting electrode W was attached to a Dolezalek electrometer E . The various components of the system were carefully screened electrically.

Now the potential of I_2 alternated from about $-10,000$ volts to $+10,000$ volts with a frequency of sixty cycles inducing an alternating potential on I_1 and P . The resistance R was so high as not greatly to affect this rise and fall of potential. Because of the jumping of the spark the potential of I_2 did not alternate sinusoidally and P changed in a manner diagrammatically indicated by

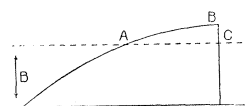

Fig. 2.

Fig. 2. The voltage rose to a maximum negative value every other half-cycle sinusoidally and then dropped suddenly to zero because of the breakdown of the spark gap resistance. The bias battery B maintained the grid G at a negative potential indicated by the dotted line so that only during a portion ABC of the negative half-cycle was the plate negative with respect to the grid—and during this time only electrons ejected from P passed over through the grid to the collecting electrode W . The drop in voltage BC of the plate was very sudden, occurring at a time after the spark discharge equal to the electrical path connecting the plate to the spark gap inductively through I_1 and I_2 divided by the velocity of light. Thus, the arrangement was such that the electric field drawing electrons from P to G could be reversed very quickly at various times subsequent to the beginning of the spark discharge by varying the length of wire T_p connecting I_2 to SG .

The flashes of light produced by the electro-optical shutter began and ended at definite times relative to the beginning of the spark. The time variation of emission of electrons by the flashes was therefore studied by observing the variation of electron current received by W with change of the time of reversal of the electric field between P and G . Clearly, if the wire paths T_p were so short that the field reversed before the light flash illuminated the surface no photo-electrons would reach W . Determining what length of wire was necessary to obtain an appreciable photoelectric current to the electrometer was therefore a measure of the instant at which the electrons first were emitted from the plate P . By further increasing the length of T_p in small steps the relative number of photoelectrons emitted during the course of the light flash and subsequent thereto was studied.

APPARATUS

Electro-optical shutter. The Kerr cell plates of K_1 and K_2 were 8 cms long, 1 cm wide and were separated 0.5 cm, both pairs being in a single Pyrex tube containing carbon bisulphide. Thin microscope cover glasses sealed on the ends of the tube by water glass provided strain free windows, ordinary so-called strain-free optical glass being quite unsuitable for the purpose. A zinc spark gap was the source of light.

Photoelectric cell. The three electrodes of the photoelectric cell were of nickel, a semi-cylindrical plate P being mounted coaxially with a grid G which completely enclosed the collecting electrode W . The grid was a nickel cylinder of 6 mm in diameter and the distance between the plate and grid was 7 mm. The collecting electrode not only was screened by the grid but also was shielded by a copper guard-ring insealed both inside and outside. The cell was evacuated and carefully baked out prior to the formation of the potassium hydride surface on P —with the result that after sealing off the cell a very good vacuum was maintained. Because of the high vacuum and the existence of solid potassium metal in the tube, all metal parts became equally photoelectrically active in the course of a few days—even the hydride surface did not retain its characteristic photoelectric properties. Thus only during the first few days was the photoelectric sensitivity of P large in com-

parison to that of G —an essential condition for satisfactory performance, for obviously stray light scattered on the grid caused spurious emission of electrons.

EXPERIMENTAL OBSERVATIONS

Fig. 3 is a plot of the photoelectric currents to the collector W (ordinates) corresponding to various times of reversal of the electric field between P and G after the beginning of the spark discharge (abscissas). It is seen that

as the time of cut-off of the photoelectric emission is delayed the current gradually increases to a point A where there is a more rapid rise of current with further delay of cut-off until a point B is reached where the photoelectric current no longer increases. Measuring the length of wire connecting the Kerr cells to the spark gap and noting the light path distance from the Kerr cells to the photoelectric cell it was estimated that the light flash began irradiating the plate P and

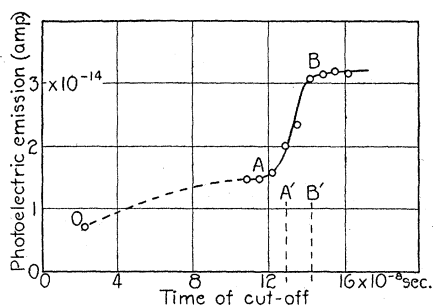

Fig. 3. Photoelectric currents to the collector for various times of cut-off after beginning of spark.

reached maximum intensity at times indicated by the dotted lines A' and B' . It is seen that the marked change of slope of the experimental curve coincides approximately with the beginning of the light flash. It is evident, therefore, that the increased slope is due to photoelectrons ejected by the flash of light and, indeed, the coincidence of the beginning of the light flash with the change of slope leads to the conclusion that photoelectric emission begins directly a metal surface is irradiated. It is important to emphasize that in this experiment the measured times of beginning of the light flash and the beginning of the photo-electron emission were 13×10^{-8} sec. and 12.5×10^{-8} sec. respectively and therefore were equal to within 4 percent.

For some time the cause of the quite appreciable emission of electrons prior to the beginning of the light flash, represented by the portion of the curve from O to A , was a mystery. It was finally discovered that the spurious current was actually due to light passing through the shutter before the main flash started. It was found that although the shutter completely extinguished the light when the wire paths to the cells were equal, they failed to charge up to the same voltage when the leads T_1 and T_2 were of different lengths.

To eliminate this troublesome circumstance the wire paths were shortened a great deal thereby causing a flash to be produced during a much earlier stage of the spark. With this arrangement the data of Fig. 4 were obtained. Again the ordinates represent the photoelectric emission corresponding to various times of cut-off after the beginning of the spark. With a bias potential of 315 volts the inductor I_2 was so placed relative to I_1 that the induced potential on P was just sufficient to enable photo-electrons to pass

from P to G when I_2 was near its maximum negative potential. The bias was then reduced to 290 volts so that the photo-electrons were drawn from P to G by a potential difference of approximately 25 volts for a short time before the reversal of the electric field. Under these conditions the data of curve A were obtained. Next the bias voltage was further reduced to 266 volts so that the potential difference accelerating electrons from P to G was 49 volts, yielding the data of curve B . Curve C resulted from changing the bias to 243 volts. The time of beginning of the light flash is represented by the dotted line X , being the wire path T_1 plus the light path from the Kerr cells to the photoelectric cell divided by the velocity of light. Likewise the flash attained maximum intensity at a time subsequent to the beginning of the spark equal to the wire path T_2 plus the light path from the cells to

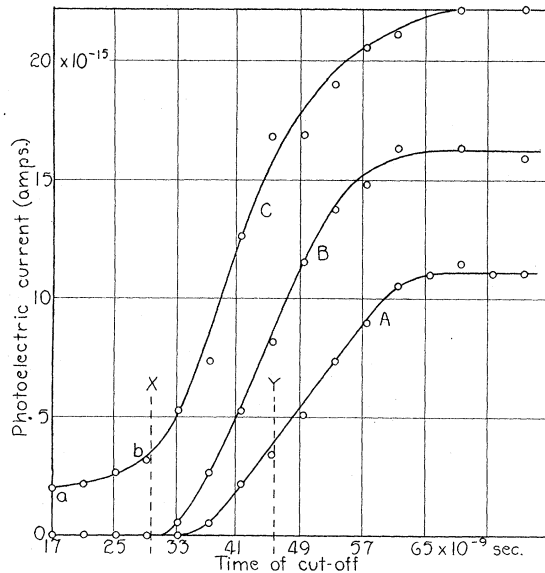

Fig. 4. Photoelectric currents to the collector for various times of cut-off after the beginning of the spark.

the photoelectric cell divided by the velocity of light, also recorded in Fig. 5 by the dotted line Y . A paper in process of publication⁴ makes clear that there is no appreciable lag in the Kerr effect but that quite appreciable intervals of time required to discharge the Kerr cells affect the operation of the shutter in such a way that it does not cut off the light sharply at the instant that the second of the Kerr cells begins discharging. Assuming there exists no persistence of the electron emission after the surface is illuminated, the data indicate that the shutter continued to allow light to pass through for about 10^{-8} sec after the second Kerr cell began discharging. This estimate of the rate of decay of the double refraction in the Kerr cells is somewhat larger than the value arrived at in the recent independent investigation cited above. However, the uncertainty in the functioning of the shutter

makes it impossible to conclude with great precision that the photoelectric emission stops as abruptly with the illumination as it commences. It can be stated with confidence only that the sum of the time required for the double refraction in the Kerr cells to decay to a small value and the time that the photo-electron emission persists after the illumination is cut off is less than 10^{-8} sec.

Of even greater importance is the interpretation of the observations of the beginning of the electron emission. It is seen that the apparent beginning of the electron emission is not the same for the three sets of data embodied in curves *A*, *B*, and *C*. Because of the finite time required for the electrons to pass from *P* to *G* a correction to the apparent time of cut-off of the electron current is necessary. The magnitude of this correction is of course readily computed from the dimensions of *P* and *G* and the potential difference between *P* and *G* drawing the electrons to *G*. Including this correction the following times of beginning of the photo-electron emission are obtained from the data of Fig. 5.

Curve	Accelerating potential between <i>P</i> and <i>G</i>	Apparent time of beginning of photo-electric emission prior to time of beginning of light flash.
<i>A</i> *	25 volts	0.8×10^{-9} sec.
<i>B</i>	49	2.6×10^{-9} sec.
<i>C</i>	72	4.5×10^{-9} sec.

The data indicate that with a large bias voltage and consequent small potential change of I_2 necessary to cut off the photoelectric current it appears that the electron emission began very nearly at the same instant the illumination commenced. Curves *B* and *C* indicate that for greater differences between the bias voltage and induced voltage the electron emission apparently began before the illumination. This is to be explained by the finite rate of fall of potential of *P* resulting from the discharge wave from the spark gap reaching the inductor I_2 . Rogowski, Flegler and Tamm⁴ have carried through some experiments which indicate that such traveling wave-fronts along wires are steeper than they were able to measure (10^{-8} sec). The present experiments are really the first definite observations of the steepness of such wave-fronts. The shift of the apparent time of beginning of the electron emission by 4.5×10^{-9} sec when the bias voltage was decreased from 315 volts to 243 volts shows that the traveling wave from the spark lowered the potential of *P* by 72 volts in about 4.5×10^{-9} sec. Because of the small capacities involved it therefore is to be concluded that the potential of I_2 , as well as other points along the wire T_p , changed 45 percent of the total amount within 4.5×10^{-9} sec. after the arrival of the front of the discharge wave from the spark.

Curve *C* differs from curves *A* and *B* in that instead of the electron current rising from zero a small electron emission was evident when the

⁴ A very interesting study of traveling wave fronts by Rogowski, Flegler and Tamm (Archiv. f. Elektrot. 18, 479 (1927)) is reviewed in a paper in process of publication in the Journal of the Franklin Institute.

photoelectric cell was presumably "cutting off" well before the beginning of the light flash (see portion *ab* of the curve). This was due to the greatest source of trouble in the experiments—oscillations. The photoelectric cell was the seat of troublesome high frequency oscillations. The difficulty was met, as curves *A* and *B* indicate, by using a high bias voltage so that the oscillations of the potential of *P* after the arrival of the discharge wave were not great enough again to give rise to a potential difference accelerating electrons to *G*. In the instance of curve *C* where the voltage, because of the low bias, had to drop 72 volts before the field between *P* and *G* reversed, the potential of *P* oscillated back again to an intermediate value during the light flash, and as a result electrons were drawn to *G* as the portion of the curve *ab* indicates. The photoelectric cell was not the only seat of troublesome oscillations and very elaborate precautions were necessary in the way of screening. Because of the very small photoelectric emission and the very sudden changes in potential of various parts of the circuit, spurious effects were always in evidence in the early stages of the experimental work and it seemed an impossible task to arrive at trustworthy results. However, all sources of trouble were ultimately eliminated and the present results are believed to be entirely reliable.

A general survey of the possible sources of systematic error in the present work leads to the conclusion that the observed highly precise coincidence of the beginning of the light flash and the beginning of the electron emission—within 0.8×10^{-9} sec. in the case of curve *A*—is probably fortuitous, the experiments being unable to detect with certainty a difference less than 3×10^{-9} sec. However, within these limits the photoelectric effect is instantaneous.

DISCUSSION

The old quantum theory of the photoelectric effect was based essentially on the Einstein photoelectric equation yielding, with the aid of thermodynamics, general statistical laws which govern such atomic processes. Just as the old theory was not able to predict the time rate of decay of radiation from a group of excited atoms, it did not concern itself with the time required for absorption of light and emission of an electron. Similar remarks apply to a wave mechanics theory of the photoelectric effect worked out by Wentzel.⁵ Wentzel has obtained a solution of the Schroedinger wave equation for the case of an atom perturbed by the electromagnetic field of an infinite plane wave train. For such a steady periodic perturbation of the atom a solution for ψ is obtained which is interpreted as an emission of an electron. However, the case of a limited wave train is not treated and, indeed, there is no way of telling how soon the atom gets into the steady perturbed state corresponding to this ψ solution after it is irradiated by light of a definite frequency. The Bohr theory regards the absorption of light as a process distinct from emission wherein an electron is raised to an outer orbit in the

⁵ Wentzel, *Zeits. f. Physik* **40**, 574 (1926).

atom, the emission of light occurring when the electron returns to its normal position. The photoelectric effect on this view is a particular case of light absorption in which the electron is removed completely from the atom. Recent experiments by d'E. Atkinson⁶ have indicated that the excitation of an atom takes place in less than 10^{-10} sec. It is therefore to be expected on the Bohr idea that photo-electrons are ejected within a similar small interval of time after illumination—as the present experiments indicate.

The exponential decay of the radiation from a group of excited atoms observed by Wien and Dempster may be interpreted in two ways. Either individual atoms give off their radiation in this manner or they emit the radiation in very short intervals of time and that what was observed was the decay-curve of those atoms that were in the initial state for the radiation in question. Recent experiments by Trautenberg and Gebauer⁷ have shown that a group of excited atoms moving with high velocity through an inhomogeneous electric field at each point of their path give off radiation having Stark effects corresponding to the electric field there. These observations clearly suggest that the latter of the above alternative hypotheses is correct—that atoms emit quanta of radiant energy practically instantly at quite appreciable times subsequent to excitation. Now if the photoelectric effect is regarded as a process of light absorption and subsequent emission by the atom of the absorbed energy in the form of an electron instead of a light quantum it is therefore natural to expect that photoelectric emission would persist after illumination of a metal surface. Because of the uncertainty of the rapidity with which the electro-optical shutter cut off the light in the present experiments it is impossible to determine with great precision whether or not such a persistence of the photoelectric effect exists. It can only be said that such an effect becomes inappreciable within 10^{-8} sec. after cessation of the illumination.

Slack⁸ using a method devised by Webb has studied the duration of radiation produced by 10.2 volt electron impacts in hydrogen. The interpretation of his results rests on the assumption of the non-existence of a lag in the photoelectric effect. The present research has shown that this assumption is valid.

SLOANE LABORATORY,
YALE UNIVERSITY,
June 10, 1928.

⁶ d'E. Atkinson, Roy. Soc. Proc. **A116**, 81 (1927).

⁷ Trautenberg and Gebauer, Zeits. f. Physik. **44**, 11–12, 768 (1927).

⁸ Slack, Phys. Rev. **28**, 1 (1926).